

Fixed displacement vane pump

PVH Series 1X

RE 10338

Edition: 05/2015

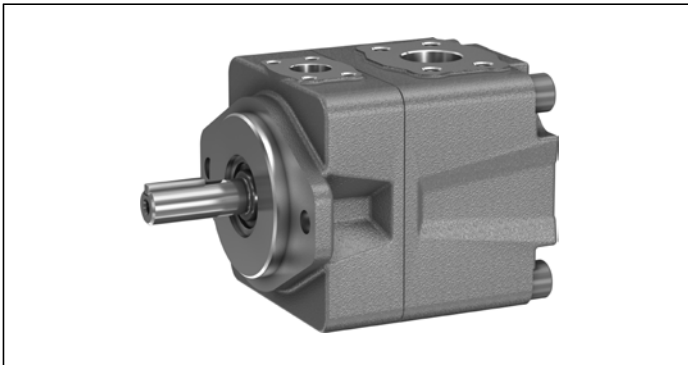

- ▶ Fixed displacement
- ▶ Frame sizes 1 and 2
- ▶ Sizes 16 to 79
- ▶ Nominal pressure 290 bar
- ▶ Peak pressure 320 bar
- ▶ Displacement volume 16 to 79 cm³

Features

- ▶ High bearing life due to hydraulically-balanced drive shaft
- ▶ Low wear due to hydraulically-balanced vanes
- ▶ Low operating noise
- ▶ Easy to service thanks to exchangeable pump cartridges
- ▶ Good efficiency level
- ▶ Position of the suction port selectable
- ▶ Clockwise and counter-clockwise drive rotation
- ▶ Drive shaft either cylindrical or splined
- ▶ Use:
For drives with high working pressure, for example, press brakes

Contents

Type code	2
Functional description	3
Technical data	4
Dimensions frame sizes 1 and 2	5
Pump cartridges for PVH	6
SAE connection flanges	7
Pump safety block	7
General project planning notes	8
Hydraulic project planning	8
Mechanical project planning	10
Maintenance schedule and operational safety	11
Accessories	11



Type code

01	02	03		04	05	06	07	08	09	10	11	12
PV	H		-	1X	/			15				

Model

01	Vane pump, fixed displacement	PV
----	-------------------------------	-----------

Series

02	High pressure pump	H
----	--------------------	----------

Frame size (BG)

03	BG1	1
	BG2	2

Series

04	Series 10 to 19 (10 to 19: unchanged installation and connection dimensions)	1X
----	--	-----------

Size (NG)

		016	020	023	025	028	032	035	041	045	050	058	064	070	079
05	Size 1	●	●	●	●	●	●	●	-	-	-	-	-	-	-
	Size 2	●	●	●	●	●	●	●	●	●	●	●	●	●	●

Direction of rotation

06	Viewed from drive shaft	clockwise	R
		counter-clockwise	L

Drive shaft

07	Parallel keyed shaft DIN 6885	A
	Splined shaft to SAE J744 with involute tooth system to ANSI B92.1a	J

Line connection

08	Suction and pressure port according to SAE J518; standard pressure series	15
----	---	-----------

Location of the suction port (with a view toward the drive shaft)

09	Above (0° from pressure port)	D
	Below (180° from pressure port)	U
	Right (90° to the right of pressure port)	R
	Left (90° to the left of pressure port)	L

Sealing material

10	NBR (nitrile rubber)	M
	FKM (fluoroelastomer)	V

Mounting flange

11	101-2 (SAE B)	B
	More on request	*

12	Specifications in plain text	*
----	------------------------------	----------

● = Available – = Not available

Preferred types PVH-1X

Model	Material number
PVH1-1X/028RA15UMB	R901416797
PVH2-1X/035RA15UMB	R901416798
PVH2-1X/045RA15UMB	R901416799
PVH2-1X/058RA15UMB	R901416800
PVH2-1X/070RA15UMB	R901416801

Functional description

Functional diagram

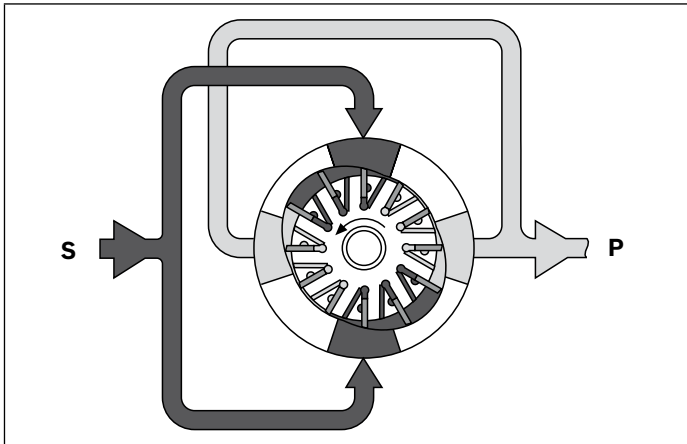

Hydraulic pumps of type PVH are vane pumps with fixed displacement volume.

The rotor (2), which turns within a stator ring (3), sits on the teeth section of the drive shaft (1). In the slots of the rotor are the vanes (4), which are pressed by centrifugal force against the inner surface of the stator ring while the rotor turns. The displacement chambers are sealed laterally by the control plates (5). Thanks to the double eccentric design of the stator ring, two pressure and two suction chambers are located across from each other, thus hydraulically balancing the shaft. It therefore only has to handle the torque. The vanes are partially unburdened when passing through the suction area. This relief reduces wear and ensures a high level of efficiency.

By simply removing the cover (6), the pump cartridges (comprising rotor, vanes, stator ring and control plates) can be taken out without having to remove the housing (7) from the pump support. This allows for easy maintenance and repair of the pump.

Section PVH

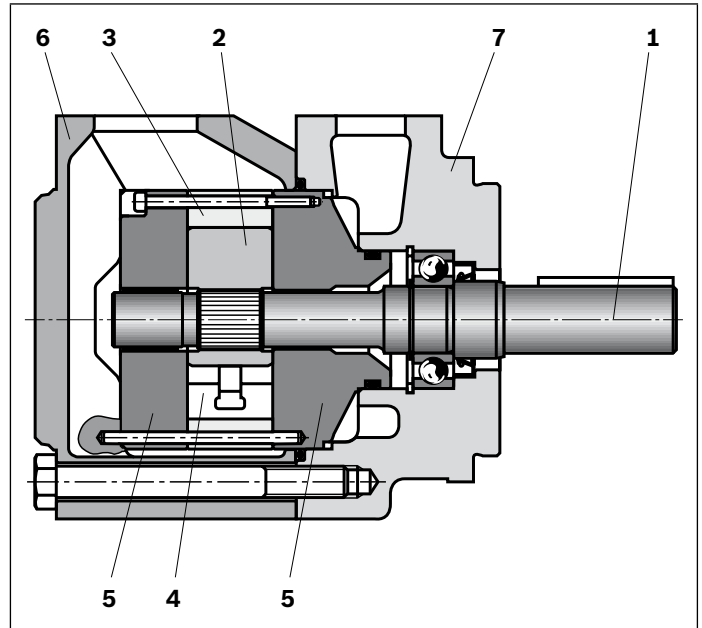

▼ Symbol

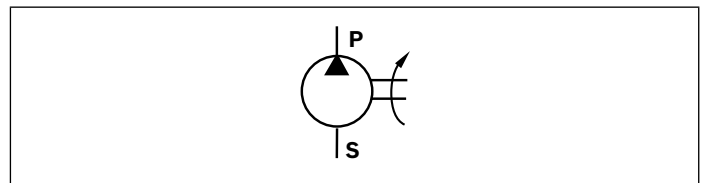

Technical data

Frame sizes 1 and 2																
Size		NG	16	20	23	25	28	32	35	41	45	50	58	64	70	79
Displacement geometrical	V_g	cm ³	15.9	19.8	22.5	24.9	28	31.8	35	41	45	50	58.3	63.8	70.3	79.3
Rotational speed ¹⁾	minimum	n_{min}	rpm	600	600	600	600	600	600	600	600	600	600	600	600	600
	maximum	n_{max}	rpm	3600	3600	3600	3600	3600	3600	3000	3000	3000	2800	2800	2800	2500
Working pressure absolute ²⁾	continuous	p_N	bar	290	290	290	290	290	290	270	270	270	240	240	240	240
	intermittent	P_{max}	bar	320	320	320	320	320	320	300	300	300	275	275	275	275
Flow maximum at 1500 rpm	q_v	l/min	23.5	29.3	33.2	36.8	41.4	47.0	51.7	60.6	66.5	73.9	86.1	94.3	103.9	117
Weight	m	kg	23	23	23	23	23	23	23	23	23	23	23	23	23	23
Mounting style	Flange mounting															

Hydraulic fluid			
Standard fluid	HLP mineral oil according to DIN 51524 Part 2		
Special fluid	<ul style="list-style-type: none"> ▶ Fire resistant anhydrous fluids HFD according to ISO 12922 ▶ Water-based polymer solution HFC according to ISO 12922 (reduced working pressure: 175/140 bar) ▶ Observe our application instructions and application requirements in the data sheets 90220 (HLP), 90222 (HFD) and 90223 (HFC). 		
Temperature range	θ	°C	-10 to +80 +30 to +60 recommended (as per viscosity range)
Viscosity range	ν	mm ² /s	13 to 54 54 to 860 with 50 % of pressure and only at the start
Maximum admissible degree of contamination of the hydraulic fluid	Class 20/18/15 ³⁾		
Cleanliness level according to ISO 4406 (c)			

▼ Loss flow, pressure-dependent

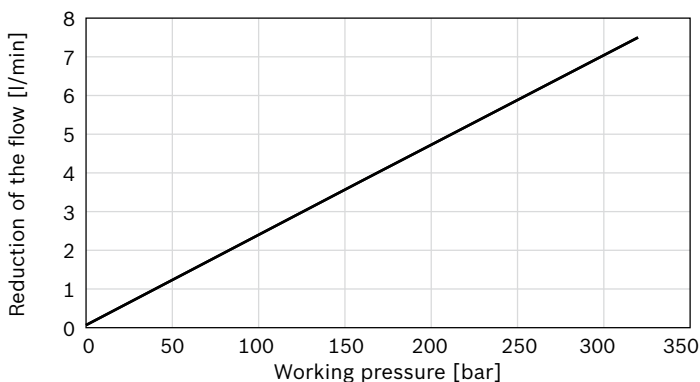

Note

- ▶ Please contact us if the unit is to be used outside the specified values.
- ▶ Characteristics measured at $\nu = 41 \text{ mm}^2/\text{s}$; $\theta = 50 \text{ °C}$

1) The values apply at absolute pressure $p_{abs} = 1 \text{ bar}$ at suction port **S**.

2) The values apply for HLP mineral oil according to DIN 51524 Part 2

3) Cleanliness levels specified for the components must be maintained in the hydraulic systems. Effective filtration prevents malfunctions and simultaneously extends the service life of the components. For the selection of the filters see data sheets 50070, 50076, 50081, 50086, 50087 and 50088.

Dimensions frame sizes 1 and 2

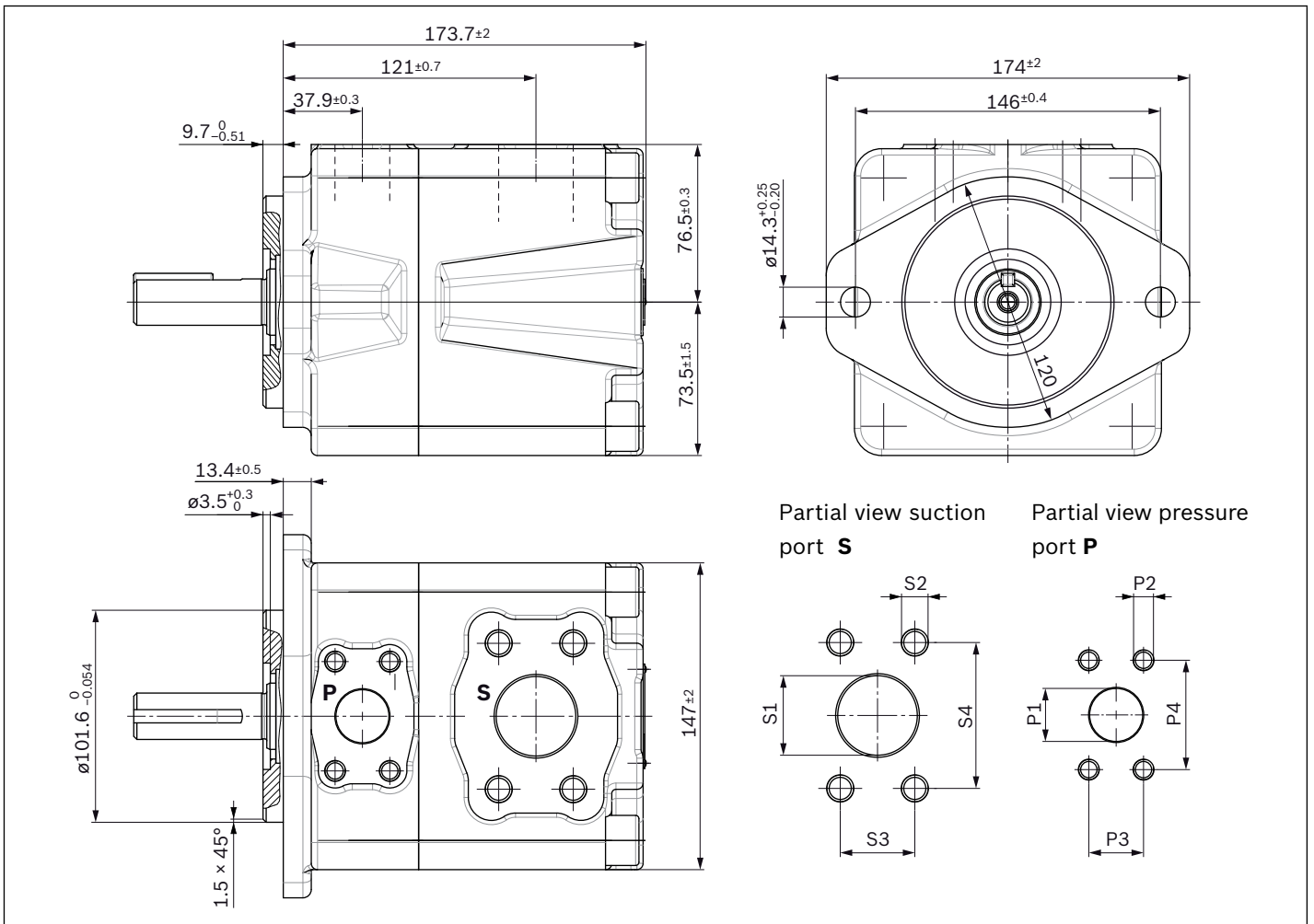

▼ **Ports according to SAE J518**

	Suction port					Pressure port				
	S	S1	S2	S3	S4	P	P1	P2	P3	P4
BG1	1 1/4 in	31.8	7/16 in - 14 UNC; 24 deep	30.2	58.7	3/4 in	19.1	3/8 in -16 UNC; 21 deep	22.2	47.6
BG2	1 1/2 in	38.1	1/2 in - 13 UNC; 24 deep	35.7	69.9	1 in	25.5	3/8 in -16 UNC; 21 deep	26.2	52.4

▼ **Parallel keyed shaft, DIN 6885 6.35 x 38**

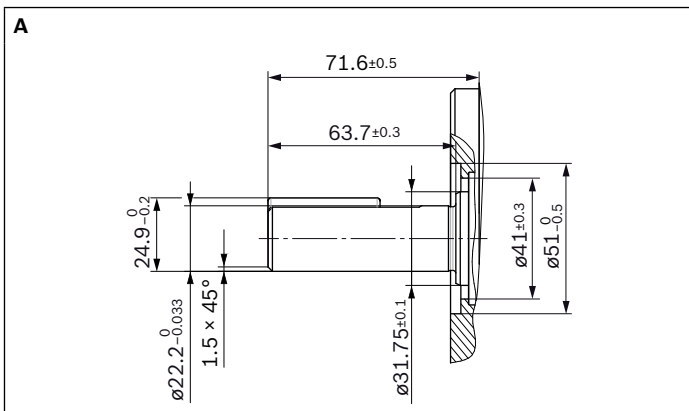

▼ **Splined shaft SAE J744**

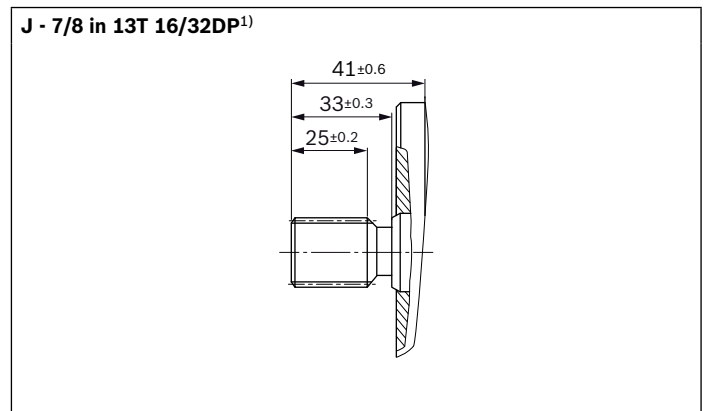

1) Involute spline according to ANSI B92.1a, 30° pressure angle, flat root, side fit, tolerance class 5

Pump cartridges for PVH



Features

- ▶ Easy to service thanks to exchangeable pump cartridges
- ▶ The stroke volume can be adjusted by replacing the pump cartridges. For size 1 hydraulic connections, only cartridges of sizes 16 to 35 are to be used.

Type code

	01	02	03		04		05	06
Mounting Kit	PV	H	2	-	1X	/		

Model

01	Vane pump, fixed displacement	PV
----	-------------------------------	-----------

Series

02	High pressure pump	H
----	--------------------	----------

Frame size (BG)

03	BG 2	2
----	------	----------

Series

04	Series 10 to 19 (10 to 19: unchanged installation and connection dimensions)	1X
----	--	-----------

Size (NG)

		016	020	023	025	028	032	035	041	045	050	058	064	070	079
05	Size 2	•	•	•	•	•	•	•	•	•	•	•	•	•	•

Direction of rotation

06	Direction of rotation (with view to drive shaft)	clockwise	R
		counter-clockwise	L

SAE connection flanges

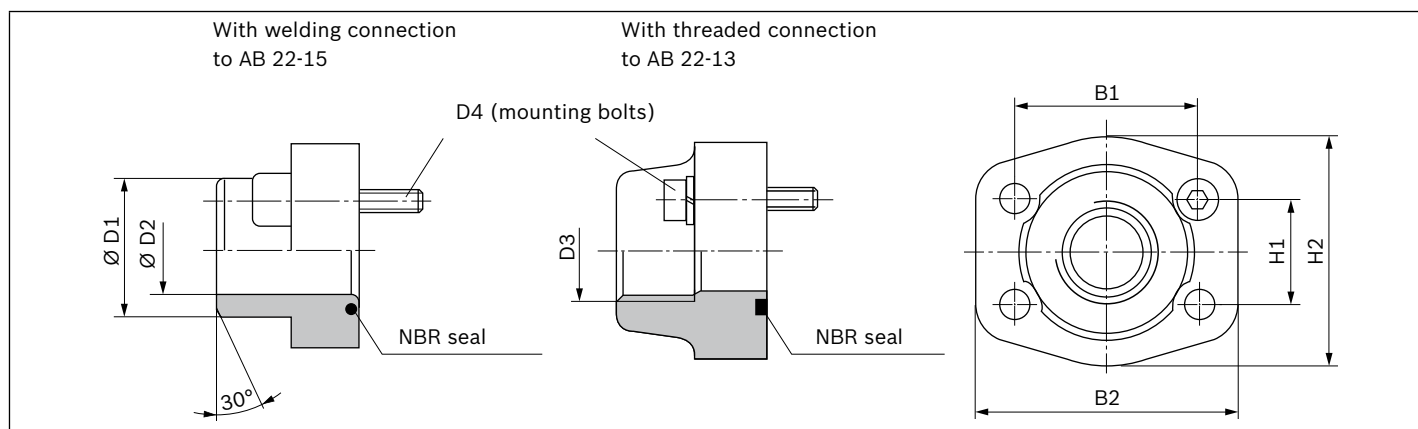

PVH	Suction flange	Pressure flange	Flange NG, pressure	Material number ¹⁾ for flange with		Dimensioning							
				Welding port	Threaded connection ²⁾	B1	B2	H1	H2	D1	D2	D3	D4
-	BG1	BG1	3/4 in 3000 psi	On request	R900063050	47.6	65	22.2	52	25	19	G3/4	3/8 in -16 UNC
-	BG2	BG2	1 in 3000 psi	On request	R900211175 ³⁾	52.4	70	26.2	59	30	22	G1	3/8 in -16 UNC
BG1	-	-	1 1/4 in 3000 psi	R900211363	R900211172	58.7	79	30.2	68	38	28	G1 1/4	7/16 in - 14 UNC
BG2	-	-	1 1/2 in 3000 psi	R900211168	R900211171	69.9	95	35.7	76	38	30	G1 1/2	1/2 in - 13 UNC

Pump safety block

For limitation of the working pressure or (and) for solenoid-actuated relief of working pressure we recommend our pump-pressure-safety-block to data sheets 25880 and 25891.

1) The material numbers comprise the flange, the O-ring (NBR) and the mounting bolts.
 2) Pipe thread "G" according to DIN EN ISO 228/1
 3) For sizes 16 to 32, the maximum working pressure for this connection flange of 315 bar must be observed.

General project planning notes

Intended use

Vane pumps are intended for the assembly of hydraulic drive systems in machine and system construction.

Technical data

The system or machine manufacturer must ensure compliance with the permissible technical data and operating conditions. The pump itself does not contain a device to prevent operation outside the permissible data. It is possible to operate the pump outside of the permissible technical data to a certain extent; the express written consent from Bosch Rexroth is, however, required.

All specified technical performance features are median values and apply with the specified general conditions. In case of modifications to the general conditions (e.g., viscosity), the technical data may change as well. Scatter corresponding to the relevant state of technology is possible.

Hydraulic project planning

Air bleeding option for commissioning

For Rexroth PVH vane pumps, a manual or switchable air bleeding option for the initial commissioning or any recommissioning after maintenance and repair work is to be provided. The air bleeding point is to be set in the pressure line before the first valve or check valve. Air bleeding may be performed with a maximum counter pressure of 0.2 bar.

Examples of air bleeding circuits

▼ Switchable air bleeding

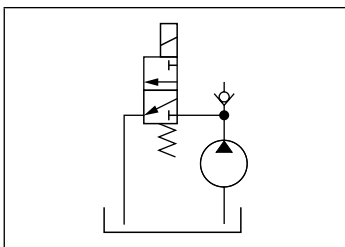

▼ Manually actuated air bleeding

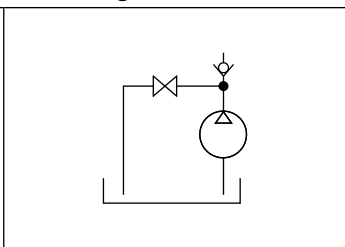

Suction line

The line cross sections are to be dimensioned for the specified flows such that an ideal suction speed of 0.6 to 1.2 m/s is achieved on average. The suction speed should not exceed a maximum value of 2 m/s.

The suction cross sections at the pump itself are designed for the maximum flow and therefore serve only as reference. In case of continuous operation at rotational speeds lower than the permissible maximum speed, the suction tube diameter is also to be dimensioned smaller than the suction port of the pump depending on the actual suction speed. Overall, the suction line is to be designed so that the permissible inlet working pressure is maintained. Bends and a combination of suction pipes from several pumps are to be avoided. If the use of a suction filter is unavoidable, it must be ensured on the system side that the lowest permissible inlet working pressure is not exceeded even if the filter is contaminated.

Ensure the air tightness of the transitions and the pressure resistance of the suction hose with respect to the external air pressure.

The immersion depth of the suction pipe should be selected as large as possible (at least 100 mm at the lowest fluid level). Depending on the internal reservoir pressure, the viscosity of the operating medium and the flow conditions within the reservoir, no vortex may form even at maximum flow. There is otherwise a risk of air being drawn in. Return fluid and case drain fluid must not be immediately be drawn in again.

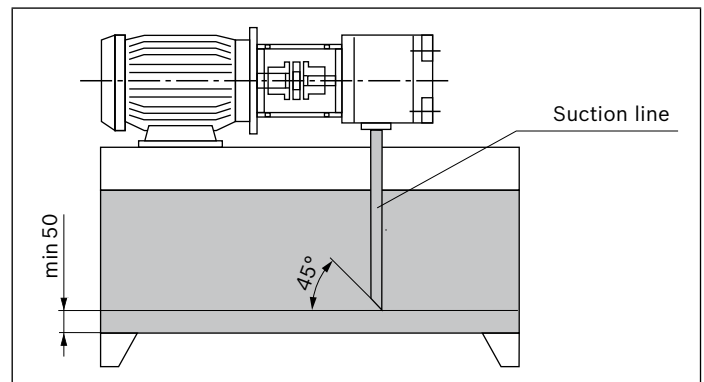

Pressure line

Sufficient burst resistance of the pipes, hoses and connecting elements must be ensured for pressure lines. The cross sections should be based on the maximum flow in order to avoid additional excessive loading of the pump due to back-pressure. Here, you must also take into account the pipe losses over the entire pressure line length and other line resistances (e.g., bends, pressure filters).

Pressure safeguarding

The PVH vane pump does not include any devices for adherence to the maximum working pressure. The setting and safeguarding of the permissible working pressure must be ensured on the system side.

The pressure-relief valves necessary for this purpose are to be designed with consideration given to the maximum flow and the rate of pressure increase that will occur such that the permissible intermittent working pressure is not exceeded.

Mechanical project planning

Mounting

On the machine side, the screws have to be accessible so that the required tightening torque can be applied. The screw tightening torque is oriented towards the operating conditions and elements involved in the screw connection and is to be specified by the manufacturer during project planning of the power unit, the machine, or the system.

Reservoir

When designing the reservoir or selecting a suitable standard reservoir, the following requirements are to be observed:

- ▶ Select the largest possible reservoir volume, depending on the continuous or average flow, which is needed in order to allow separation of air bubbles by means of sufficient dwell time of the medium in the reservoir. The air separation ability of the used hydraulic fluid is also of importance here.
- ▶ Provide settling zones for the hydraulic fluid in the reservoir in order to allow for air separation.
- ▶ Provide guiding plates in order to allow contamination at the reservoir bottom to be deposited outside the pump suction area.
- ▶ Generously dimension the reservoir surfaces depending on the heat output to be dissipated via the reservoir walls.

Required power unit functions

At a minimum, the hydraulic power units should be equipped with the following features:

- ▶ Reservoirs that are designed so that the internal pressure corresponds to the ambient pressure should be equipped with ventilation filters for pressure compensation purposes.
- ▶ The hydraulic fluid should only be filled using filling nozzles that eliminate the possibility of filling with unfiltered fluid.
- ▶ The ingress of contamination or moisture must be avoided. If used in highly contaminated environments, the reservoir must, for this purpose, be precharged by means of air pressure. If cleaning of the reservoir exterior is planned or anticipated during the period of use, reservoir bushings for pipes, lines, or hoses are to be selected so that a secure seal is ensured against external pressurization with a water jet.

Place of installation and ambient conditions

With places of installation at a geodetic height of more than 1000 m, the pump is to be arranged in or below the reservoir or the reservoir is to be precharged by means of compressed air in order to ensure the permissible minimum inlet pressure. A short suction line with large cross section is to be selected; bends should not be used.

When installing the pump more than 10 m below the reservoir, the reduction of the inlet pressure to the maximum permissible value must be ensured by means of additional measures.

If operating the pump in salt-containing or corrosive environments or if there is a possibility of pressurization with strongly abrasive substances, it must be ensured on the system side that the shaft seal ring and the sealing area of the shaft do not make direct contact with the environment.

Drive

Electric motor + pump support + coupling + pump

- ▶ No radial or axial forces permissible on the pump drive shaft!
- ▶ Motor and pump must be exactly aligned!
- ▶ Always use a coupling that is suitable for compensating for shaft offsets!

Installation positions

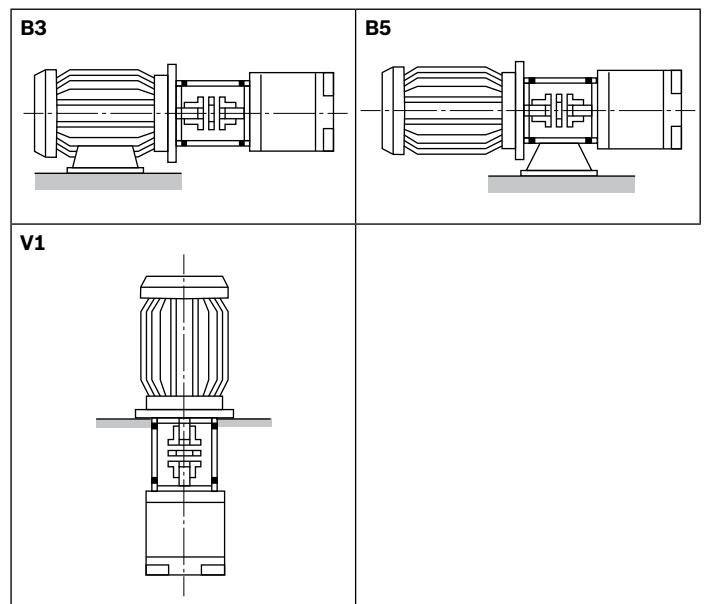

Maintenance schedule and operational safety

For safe operation and a long service life of the pump, a maintenance schedule must be prepared for the power unit, the machine, or the system. The maintenance schedule must ensure that the specified or permissible operating conditions of the pump are complied with over the entire period of use.

In particular, compliance with the following operating parameters has to be ensured:

- ▶ The required oil cleanliness
- ▶ The operating temperature range
- ▶ The filling level of the operating medium

Furthermore, the pump and the system are to be checked for changes to the following parameters on a regular basis:

- ▶ Vibrations
- ▶ Noise
- ▶ Temperature difference between pump – fluid in the reservoir
- ▶ Foaming in the reservoir
- ▶ Leak-proofness

Changes to these parameters indicate component wear (e.g., drive motor, coupling, pump, etc.). The cause has to be determined and remedied immediately.

In order to achieve high operational safety of the pump in the machine or system, we recommend checking the aforementioned parameters continuously and automatically and the automatic shut-down in case of changes exceeding the usual fluctuations in the specified operating range.

Plastic components of drive couplings should be replaced regularly, though after no more than 5 years. The corresponding manufacturer's specifications are paramount.

For preventive maintenance of the pump, we recommend having the seals replaced after an operating period of no more than 5 years by an authorized Bosch Rexroth service company.

Accessories

Pump safety block

For limiting the working pressure and for the pump circulation at zero pressure, we recommend our pump safety blocks according to data sheets 25890 and 25891.

Automatic air bleeding during commissioning is, however, not possible via DBA blocks. In this case, we recommend separate, manual air bleeding.



Bosch Rexroth AG
Mobile Applications
Zum Eisengießer 1
97816 Lohr am Main, Germany
Phone +49 9352 18-0
info.ma@boschrexroth.de
www.boschrexroth.com

© This document, as well as the data, specifications and other information set forth in it, are the exclusive property of Bosch Rexroth AG. It may not be reproduced or given to third parties without its consent. The data specified above only serve to describe the product. No statements concerning a certain condition or suitability for a certain application can be derived from this information. The information provided does not release the user from conducting their own evaluations and tests. It must be remembered that our products are subject to a natural process of wear and aging.