

Radial piston motor for track drives

MCR-T

RE 15221

Edition: 03.2017

Replaces 07.2015



- ▶ Frame size MCR5, MCR6, MCR10
- ▶ Displacement 620cc to 1340cc
- ▶ Differential pressure up to 400 bar
- ▶ Torque output up to 8530 Nm
- ▶ Speed up to 250 rpm
- ▶ Open and closed circuits

Features

- ▶ Compact robust construction
- ▶ High brake capacity
- ▶ High volumetric and mechanical efficiencies
- ▶ High pressure rating
- ▶ High reliability
- ▶ High bearing life
- ▶ Low maintenance
- ▶ Smooth running at very low speeds
- ▶ Low noise
- ▶ Freewheeling possible
- ▶ Available with
 - Integrated parking brake
 - Bi-directional two speed
 - Integrated flushing valve
 - Speed sensor

Contents

Functional description	2
Ordering code	6
Technical data	8
Dimensions	10
Selection guide	11



Siège Social Douala - Cameroun B.P. 12591 Douala
 contact@2comappro.com
 Tél : + 237 233 424 913
 et + 237 674 472 158

www.2comappro.com

Functional description

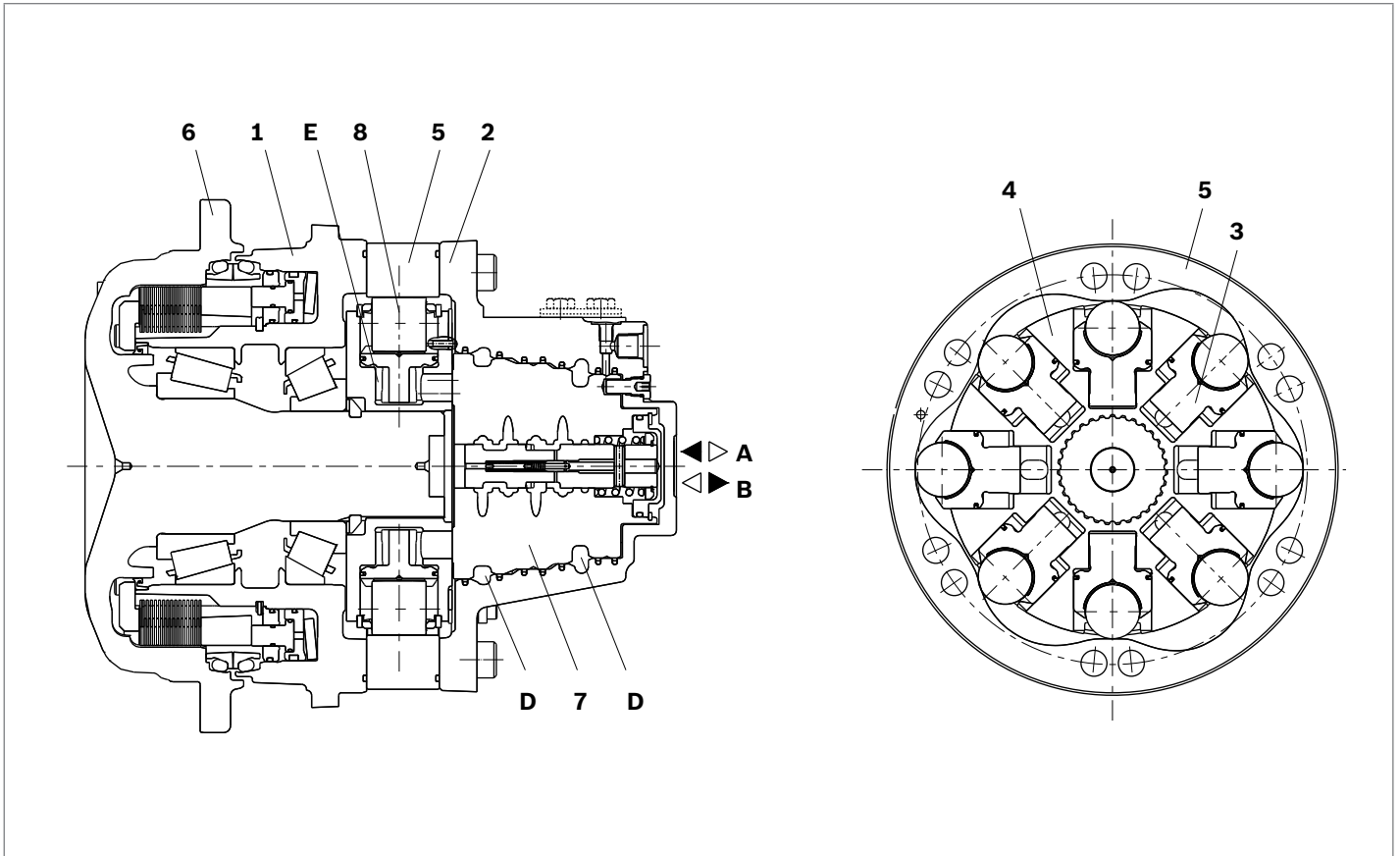

Hydraulic motors of the type MCR-T are radial piston motors with front case mounting and flanged shaft. They are specially designed for track drive applications and are primarily used as drive motors on skid-steer loaders and compact track loaders.

The MCR-T type motor can be used in open as well as closed hydraulic circuits.

Construction

Two part housing (1, 2), rotary group (3, 4, 8), cam (5), drive shaft (6) and flow distributor (7)

Transmission

The cylinder block (4) is connected to the shaft (6) by means of splines. The pistons (3) are arranged radially in the cylinder block (4) and make contact with the cam (5) via rollers (8).

Torque generation

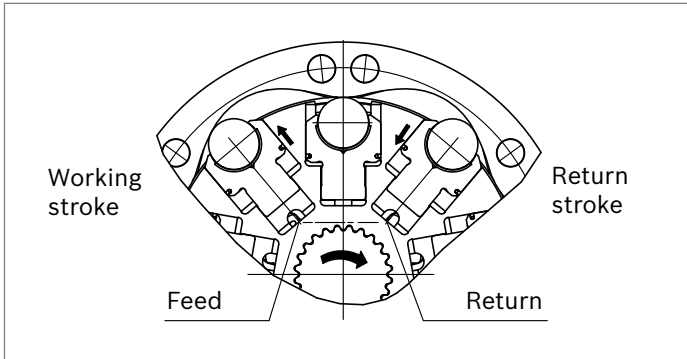

The number of working and return strokes corresponds to the number of lobes on the cam multiplied by number of pistons in the cylinder block.

Flow paths

The ports **A** and **B**, which are located in the rear case, carry oil through the distributor to the cylinder chambers (**E**).

Bearings

Tapered roller bearings capable of transmitting high axial and radial forces are fitted as standard.

Freewheeling

In certain applications there may be a requirement to freewheel the motor. This may be achieved by connecting ports **A** and **B** to zero pressure and simultaneously applying a pressure of 2 bar to the housing through port **L**. In this condition, the pistons are forced into the cylinder block which forces the rollers to loose contact with the cam thus allowing free rotation of the shaft.

Two speed operation (2W)

In mobile applications where vehicles are required to operate at high speed with low motor loads, the motor can be switched to a low-torque and high-speed mode. This is achieved by operating an integrated valve which directs hydraulic fluid to only one half of the motor while continuously re-circulating the fluid in the other half. This “reduced displacement” mode reduces the flow required for a given speed and gives the potential for cost and efficiency improvements. Maximum rated speed of the motor remains unchanged.

Bosch Rexroth has developed a special spool valve to allow smooth switching to reduced displacement whilst on the move. This is known as “soft-shift” and is a standard feature of 2W motors. The spool valve requires either an additional sequence valve or electro-proportional control to operate in “soft-shift” mode. Alternatively, enhanced soft-shifting via software control primarily for Compact Track Loader applications is now available from Bosch Rexroth.

▼ Two-speed motor

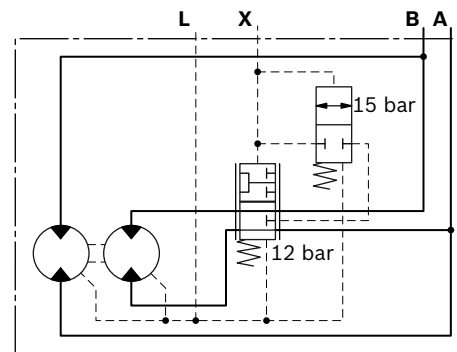

Note

2W can not be used in open circuit.

Flushing valve

In a closed circuit, the same hydraulic fluid continuously flows between the pump and the motor. This could therefore lead to overheating of the hydraulic fluid.

The function of the flushing valve option is to replace hydraulic fluid in the closed circuit with that from the reservoir. When the hydraulic motor is operated under load, either in the clockwise or counter-clockwise direction, the flushing valve opens and allows a fixed flow of fluid through an orifice from the low pressure side of the circuit. This flow is then fed to the motor housing and back to the reservoir normally via a cooler. In order to charge the low pressure side of the circuit, cold fluid is drawn from the reservoir by the boost pump and is fed to the pump inlet through the check valve. Thus the flushing valve ensures a continuous renewal and cooling of the hydraulic fluid. The flushing feature incorporates a relief valve which is used to maintain a minimum boost pressure and operates at a standard setting of 14 bar (other options available on request). Different orifice sizes may be used to select varying flows of flushing fluid. The following table gives flushing rate values based on a boost / charge pressure of 25 bar.

▼ Motor with flushing valve

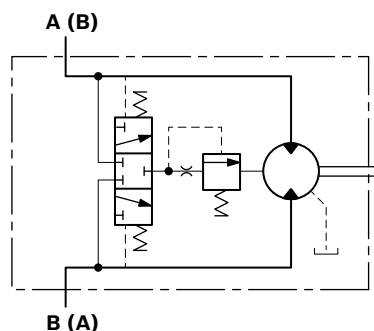

Flushing flow rates

Flushing code	Orifice size (mm)	Flow (l/min) at 25 bar ¹⁾	
		min	max
F1	ø1	2.2	2.7
F2	ø1.5	5.0	6.1
F7	ø1.7	6.4	7.8
F4	ø2	8.2	10.7
F6	ø2.3	8.8	11.4

1) 0.6 mm Shim (Standard), Cracking pressure = 11±3 bar

Holding brake (multi-disc brake)

Mounting

The MCR T-type motor has a spring applied pressure released holding brake integrated into the front of the motor.

Brake application

As a safety requirement in mobile applications a parking brake is provided to ensure that the motor cannot turn when the machine is not in use. The parking brake provides holding torque by means of discs that are compressed by a disc spring. The brake is released when oil pressure is applied to brake port "Z" and the pressure in the annular area compresses the disc spring allowing the brake discs to turn independently.

Notice

Brakes not for dynamic use!

▼ Schematic diagrams

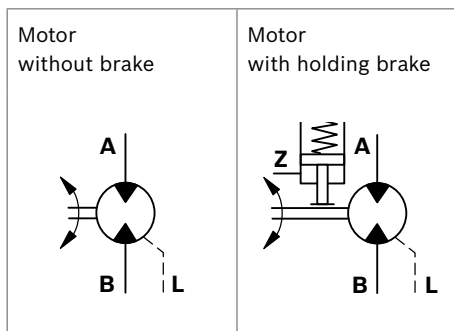

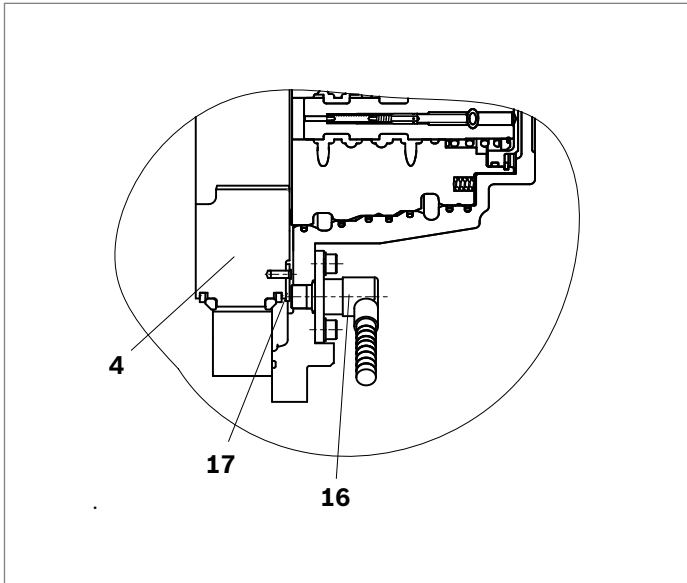
Speed sensor

A Hall-effect speed sensor (**16**) may be fitted as an option, giving a two-channel output of phase-displaced square waves, and enabling detection of speed and direction. A toothed target disc (**17**) is fitted to the motor cylinder block (**4**), and the sensor, fitted to a port in the rear case, produces a pulse on each channel as each tooth passes in front of it. The frequency of the pulses is proportional to the rotational speed.

Versions are available for use with regulated supplies 10 V (Code P1) and for direct connection to a 12 V or 24 V unregulated supply (Code P2).

The motor can also be supplied fitted with a target disc and with a speed sensor port machined, but covered and sealed with a blanking plate (Code P0). These “sensor-ready” motors may be fitted with a sensor at a later date.

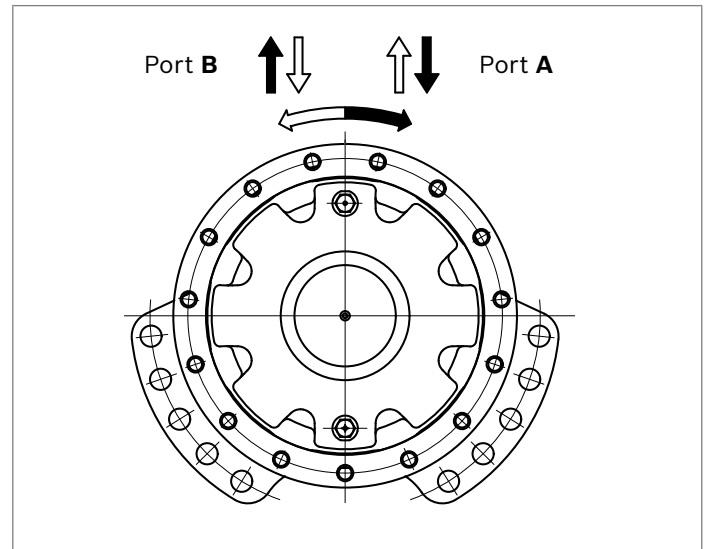
Direction of shaft rotation with flow
(viewed from drive shaft)

Ordering code

01	02	03	04	05	06	07	08	09	10	11	12	13	14	15
MCR		T			Z	/	33		V					

Radial piston motor

01	Radial-piston type, low-speed, high-torque motor	MCR
----	--	------------

Frame size

02	Frame size	5	5
		6	6
		10	10

Housing type

03	Front case flanged	T
----	--------------------	----------

Nominal size, displacement V_g in cm^3/rev

04	Frame size 5		620	680	750	820	
		High displacement: motors use stepped pistons	HD	•	•	•	•
	Frame size 6				820	920	
		High displacement: motors use stepped pistons	HD		•	•	
	Frame size 10		1070	1120	1180	1340	
		High displacement: motors use stepped pistons	1L	•	•	-	-
		High displacement: motors use stepped pistons	2W	•	•	•	•

Drive shaft

05	With flange $\varnothing 284$ mm (only available with MCR5T and MCR6T)	F284
	With flange $\varnothing 315$ mm (only available with MCR10T)	F315

Through shaft

06	Without through shaft	Z
----	-----------------------	----------

Series

07	Series 33	33
----	-----------	-----------

Brake

08	Hydraulic release spring applied multi-disc holding brake 4500 Nm	B5
	Hydraulic release spring applied multi-disc holding brake 7000 Nm (only available with MCR10T)	B7

Seals

09	FKM (fluoroelastomer / Viton)	V
----	-------------------------------	----------

Single/two-speed operation

10	Single speed, standard direction of rotation	1L
	Bi-directional two speed, standard direction of rotation	2WL

Ports

11	Tapped with UNF thread (SAE J514) (only available with MCR5T and MCR6T)	12
	Tapped with UNF thread (SAE J514) (A & B ports SAE split flange metric bolt holes) (only available with MCR10T)	48

• = Available - = Not available

01	02	03	04	05	06	07	08	09	10	11	12	13	14	15
MCR		T			Z	/	33		V					

Studs

12	Without studs (no code)	
----	-------------------------	--

Speed sensor

13	Without sensor (no code)	
	Sensor ready	P0
	Sensor without regulator	P1
	Sensor with regulator	P2

Flushing

14	Without flushing (no code)	
	With flushing (see table on page 3)	F1-F7

Special order

15	Special feature	SOXXX
----	-----------------	--------------

Technical data

Frame size			MCR5T	MCR6T	MCR10T	
Description			Radial-piston type, low-speed, high-torque motor			
Type of mounting			Flange mounting			
Pipe connections ¹⁾²⁾			Threaded per SAE J514; Flanged per SAE J518			
Weight						
Single speed (1L)	<i>m</i>	kg	58	60	84	
Two speed (2WL)	<i>m</i>	kg	63	66	93	
Two speed ratio ³⁾						
Full displacement			1:1	1:1	1:1	
Reduced displacement			1:2	2:3	1:2	
Hydraulic fluid ⁴⁾						
Fluid cleanliness			ISO 4406, Class 20/18/15			
Fluid viscosity range	$v_{\min/\max}$	mm ² /s	10 to 2000			
Fluid temperature range ⁵⁾	$\theta_{\min/\max}$	°C	-20 to +115			
Pressure						
Maximum differential pressure ⁶⁾⁷⁾			Δp_{\max}	bar	400	
Maximum pressure at port A or B ⁶⁾⁷⁾			p_{\max}	bar	420	
Maximum case drain pressure			$p_{\text{case max}}$	bar	10	
Motor performance MCR5T			Size	620	680	750 820
Displacement	V_g	cm ³ /rev	620	680	750	820
Specific torque		Nm/bar	10	11	12	13
Maximum torque ⁶⁾¹²⁾	T_{\max}	Nm	3947	4329	4775	5220
Minimum speed for smooth running ⁸⁾	n_{\min}	rpm	0.5	0.5	0.5	0.5
Maximum speed (1L) ⁹⁾¹⁰⁾	n_{\max}	rpm	250	250	230	210
Maximum speed (2WL) ⁹⁾¹⁰⁾	n_{\max}	rpm	250	250	250	230
Motor performance MCR6T			Size	820	920	
Displacement	V_g	cm ³ /rev	820	920		
Specific torque		Nm/bar	13	15		
Maximum torque ⁶⁾¹²⁾	T_{\max}	Nm	5220	5857		
Minimum speed for smooth running ⁸⁾	n_{\min}	rpm	0.5	0.5		
Maximum speed (1L) ⁹⁾¹⁰⁾	n_{\max}	rpm	230	205		
Maximum speed (2WL) ⁹⁾¹⁰⁾	n_{\max}	rpm	250	250		
Motor performance MCR10T			Size	1070	1120	1180 1340
Displacement	V_g	cm ³ /rev	1070	1120	1180	1340
Specific torque		Nm/bar	17	18	19	21
Maximum torque ⁶⁾¹²⁾	T_{\max}	Nm	6812	7130	7512	8531
Minimum speed for smooth running ⁸⁾	n_{\min}	rpm	0.5	0.5	0.5	0.5
Maximum speed (1L) ⁹⁾¹⁰⁾	n_{\max}	rpm	185	180	170	150
Maximum speed (2WL) ⁹⁾¹⁰⁾	n_{\max}	rpm	240	240	235	205

Holding brake (disc brake)	Size		B5	B7
Minimum holding torque	$T_{\min/\max}$	Nm	4500	7000
Release pressure (min) ¹³⁾	$P_{\text{rel min}}$	bar	12	10
Release pressure (max) ¹³⁾	$P_{\text{rel max}}$	bar	15	15
Maximum pressure at brake port "Z"	P_{max}	bar	40	40
Oil volume to operate brake	V_{rel}	cm ³	20	22

Notice

- ▶ Motor performance values all based on theoretical calculations.
 - ▶ Efficiencies not taken into consideration for theoretical calculations.
 - ▶ Brake torque accounts for tolerances.
- Please refer the related foot notes for more details.



Footer from page 8 and 9

- 1) Ensure motor case is filled with oil prior to start-up.
- 2) For installation and maintenance details, please see operating manual 15215-B.
- 3) Other displacements and ratios contact Bosch Rexroth.
- 4) For any other fluid type contact the Engineering Department at Bosch Rexroth, Glenrothes. For more information on hydraulic fluids, see datasheets 90220 and 90223.
- 5) Extension of the allowable temperature range may be possible depending on specification. Please consult Bosch Rexroth Engineering Department in Glenrothes for further Details.
- 6) Maximum values should only be applied for a small portion of the duty cycle. Please consult Bosch Rexroth Engineering Department in Glenrothes for motor life calculations based on particular operating cases.

- 7) When operating motors in series, please consult Bosch Rexroth Engineering Department in Glenrothes.
- 8) For continuous operation at speeds <5 rpm please consult Bosch Rexroth Engineering Department in Glenrothes.
- 9) Based on nominal no-load Δp of 20 bar in full- displacement mode.
- 10) Warning! During the running in period of the motor (min. 20 hrs) it should not be run unloaded at >100 rpm.
- 11) Guide values for up to 5000 hours of motor operation (ISO VG46 and 50°).
- 12) Low displacement = 450 bar, high displacement = 400 bar
- 13) At 0 bar case pressure, the quoted brake release pressure is over and above any case pressure present.

Dimensions

MCR5, MCR6

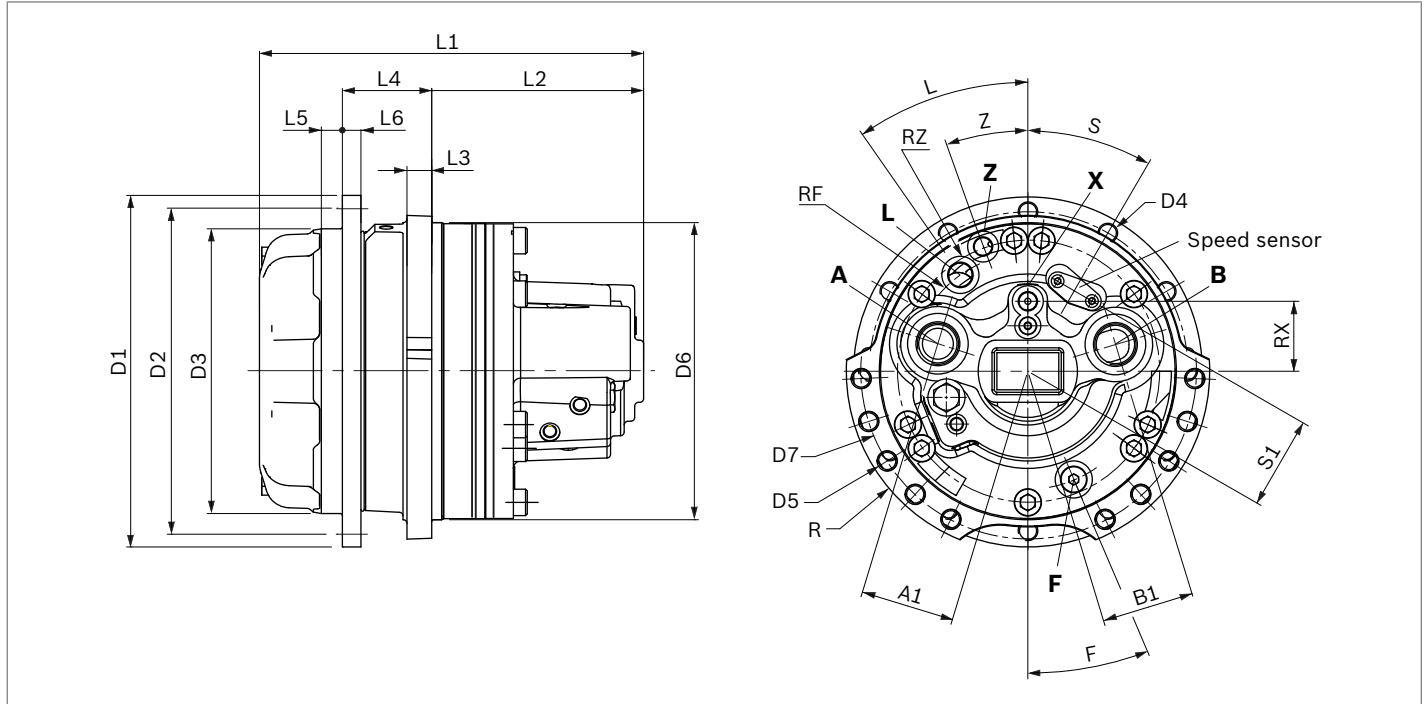

Motor	D1	D2	D3	D4	D5	D6	D7	R	L	S	Z	F
MCR5T1L	ø284	ø260	ø230	M16	ø17.5	ø240	ø322.58	148	36.5°	25°	20.7°	23°
MCR5T2WL	ø284	ø260	ø230	1/2-13 UNC 2B	ø16.5	ø230	ø264	148	30°	30°	6.5°	23°
MCR6T1L	ø284	ø260	ø230	1/2-13 UNC 2B	ø17.5	ø240	ø322.58	176.5	35°	-	19.8°	23°
MCR6T2WL	ø284	ø260	ø230	M16	ø16.5	ø240	ø272	148	35°	30°	19.8°	23°

Motor	L1	L2	L3	L4	L5	L6	RX	RZ	RF	A1	B1	S1
MCR5T1L	270	130.8	20	72.2	17	15	-	R101.5	R90	76	74	75
MCR5T2WL	310.4	171.2	20	72.2	17	15	56.5	R101	R90	76	74	75
MCR6T1L	270	130.8	20	72.2	17	15	-	R107	R95	76	74	-
MCR6T2WL	310.4	171.2	20	72.2	17	15	56.5	R107	R95	76	74	75

Ports

Designation	Port function	Ordering code 12	Size	Ordering code 48 ¹⁾	Size ¹⁾	Maximum pressure [bar]	State ²⁾
A, B	Inlet, outlet	SAE J514	1 5/16-12 UN	SAE J518	3/4 in	420	O
L	Case drain	SAE J514	3/4-16 UNF	SAE J514	3/4-16 UNF	10	O
X	2 speed port	SAE J514	9/16-18 UNF	SAE J514	9/16-18 UNF	30	O
Z	Brake port	SAE J514	9/16-18 UNF	SAE J514	9/16-18 UNF	40	O
F	Filler port	SAE J514	3/4-16 UNF	SAE J514	3/4-16 UNF	10	X

¹⁾ Applicable to MCR10T only

²⁾ O = Must be connected (plugged on delivery)

X = Plugged (in normal operation)

Before finalizing your design, request a binding installation drawing.

Dimensions

MCR10

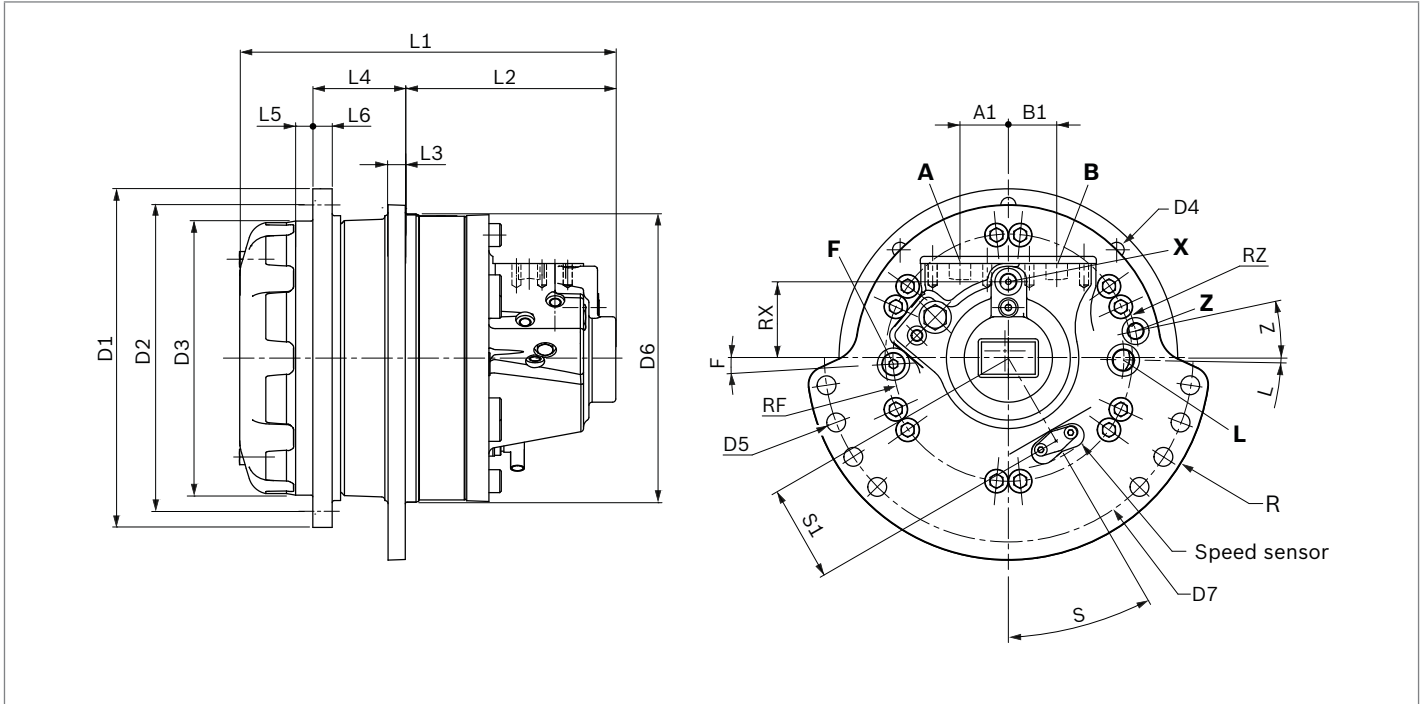

Motor	D1	D2	D3	D4	D5	D6	D7	R	L	S	Z	F
MCR10T1L	ø315	ø285	ø255	5/8-11 UNC 2	ø17.5	ø268	ø342	187.5	3°	-	10°	3°
MCR10T2WL	ø315	ø285	ø255	M16	ø17.5	ø268	ø342	187.5	1°	30°	12°	3°

Motor	L1	L2	L3	L4	L5	L6	RX	RZ	RF	A1	B1	S1
MCR10T1L	293.5	139.5	16	86	16	18	-	R121	R107	45	45	-
MCR10T2WL	349.8	195.8	16	86	16	18	71	R121	R107	45	45	89

Ports

Designation	Port function	Ordering code 12	Size	Ordering code 48 ¹⁾	Size ¹⁾	Maximum pressure [bar]	State ²⁾
A, B	Inlet, outlet	SAE J514	1 5/16-12 UN	SAE J518	3/4 in	420	O
L	Case drain	SAE J514	3/4-16 UNF	SAE J514	3/4-16 UNF	10	O
X	2 speed port	SAE J514	9/16-18 UNF	SAE J514	9/16-18 UNF	30	O
Z	Brake port	SAE J514	9/16-18 UNF	SAE J514	9/16-18 UNF	40	O
F	Filler port	SAE J514	3/4-16 UNF	SAE J514	3/4-16 UNF	10	X









¹⁾ Applicable to MCR10T only

²⁾ O = Must be connected (plugged on delivery)

X = Plugged (in normal operation)

Before finalizing your design, request a binding installation drawing.

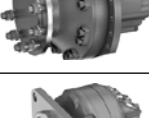
Selection guide

Data sheet	Motor type Application		Frame size					
			3 160..400 cc	5 380..820 cc	6 820..920 cc	10 780..1340 cc	15 1130..2150 cc	20 1750..3000 cc
15198	MCR-F Wheel drives		•	•	-	•	•	-
15200	MCR-W Heavy duty wheel drives		•	•	-	•	-	-
15195	MCR-A Frame integrated drives		•	•	-	•	•	-
15199	MCR-H Integrated drives		•	•	-	•	•	•
15221	MCR-T Track drives		-	•	•	•	-	-
15223	MCR-R Series 41 Hydraulic drive assist		-	-	-	•	-	-
15214	MCR-X Slew drives		•	•	-	-	-	-
15197	MCR-C Compact drives		-	-	-	-	-	•
15196	MCR-D Industrial applications		•	•	-	•	-	-
	MCR-E Industrial applications		-	•	-	-	-	-

Bosch Rexroth Limited
Viewfield Industrial Estate
Glenrothes, Fife
Scotland, KY6 2RD
UK
Phone +44 15 92 631 777
Telefax +44 15 92 631 936
www.boschrexroth.com

© Bosch Rexroth AG 2017. All rights reserved, also regarding any disposal, exploitation, reproduction, editing, distribution, as well as in the event of applications for industrial property rights. The data specified within only serves to describe the product. No statements concerning a certain condition or suitability for a certain application can be derived from our information. The information given does not release the user from the obligation of own judgment and verification. It must be remembered that our products are subject to a natural process of wear and aging.